



**PARODI**GROUP  
FOOD & HEALTH



HONEYS FROM THE WORLD  
TO THE WORLD



Distribué par:





ENERGY DRINK

**BEEBAD<sup>®</sup>**

**bad is better**

<https://www.youtube.com/watch?v=A0IPUN0wM44>



La première boisson énergisante sucré 100% avec du miel.



UNIQUE dans sa catégorie, avec des ingrédients naturels en conformité avec les nouvelles tendances du marché.



Fraîche. Insolent. Désaltérant .

## Notre objectif

Fournir une boisson énergisante avec des **ingrédients naturels**, et avec bon goût et désaltérant.

# BEEBAD® dans le Monde



## NOUS SOMMES AQUI

- ✓ BELGIQUE
- ✓ CHILI
- ✓ CHINE
- ✓ ESPAGNE
- ✓ ETHIOPIE
- ✓ FRANCE
- ✓ HOLLANDE
- ✓ IRLANDE
- ✓ ITALIE
- ✓ LUXEMBOURG
- ✓ SUISSE
- ✓ ROYAUME-UNI
- ✓ ÉTATS-UNIS D'AMÉRIQUE
- ✓ ALLEMAGNE
- ✓ AFRIQUE DU SUD

## BIENTOT

- ✓ ARABIE SAOUDITE
- ✓ AUSTRALIE
- ✓ BRÉSIL
- ✓ GUATEMALA
- ✓ INDE
- ✓ IRAN
- ✓ MALTE
- ✓ MAROC
- ✓ MYANMAR
- ✓ NORVÈGE
- ✓ SINGAPOUR
- ✓ URUGUAY



# Environnement concurrentiel

## Le marché des boissons énergisantes dans le monde

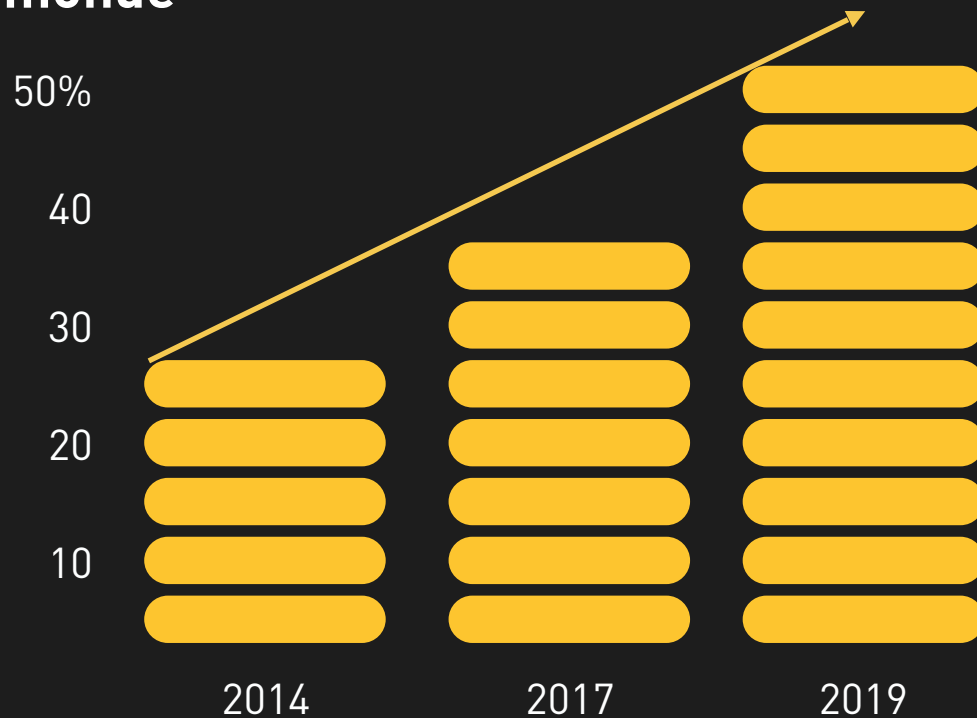

**\$50 milliards de dollars**  
est la valeur du marché des boissons énergisantes au niveau mondial.

**+52%**

est la projection de croissance du marché prévu entre 2014 et 2019.



## Le marché des boissons énergisantes en Europe



**68%**

68% des adolescents européens consomment des boissons énergisantes

**30%**

Le 30% des adultes européens consomment des boissons énergisantes

**12%**

En 2015, le 12% de la population européenne était consommateur chronique de boissons énergisantes .

**+6%**

En 2015 le marché européen des boissons énergisantes est augmenté de 6% en valeur sur 2014.

**+4,9%**

En 2015 la consommation des boissons énergisantes en Europe est augmenté de 4,9% en volume.

Font: Euromonitor



## Le marché des boissons énergisantes en Italie



**60%**

60% des adolescents italiens (11-18 ans) consomment des boissons énergisantes, tandis que 12% consomme une moyenne de 7 litres par mois.



**30%**

Il 30% des adultes italiens (18-65 ans) consomment des boissons énergisantes, tandis que 12% consomme en moyenne 4,5 litres par mois..

**56%** et le **53%**

56% des adultes et 53% des adolescents italiens consomment des boissons énergisantes mélangées avec divers alcool quand ils sortent la nuit.



**54%**

54% des Italiens ont déclaré qu'ils achèteraient boissons énergisantes si elles contiennent des ingrédients naturels

# Analyse du Produit



**BEEBAD**<sup>®</sup>

ENERGY DRINK

sweetened with  
**HONEY**

enriched with  
**ROYAL JELLY  
& PROPOLIS**

bad is better

- ✓ MADE IN ITALY
- ✓ OUI MIEL, NON SUCRE RAFFINE'
- ✓ SANS GLUTEN
- ✓ SANS TAURINE

## Produit avec des ingrédients naturellement énergisant. Bon goût, frais, doux et croustillant.

La **caféine** aide à lutter contre la fatigue et d'améliorer les réflexes et la capacité de se concentrer.

Le **miel** est la meilleure source d'énergie naturelle. Il est le résultat du travail acharné et méticuleux des abeilles, alliés de la nature et de l'écosystème. Il est la plus ancienne et la source la plus naturelle de douceur, sans produits chimiques et dangereux sucres raffinés.

La **gelée royale** est connue dans le monde entier pour ses effets énergisants et vivifiant, utiles pour lutter contre les effets du vieillissement et de stimuler le système immunitaire. Il est un véritable élixir de vie!

La **Propolis** est connue pour ses propriétés bénéfiques parmi lesquelles nous mettons en évidence les effets antibactériennes et antivirales et immunostimulantes et les antioxydants naturels, qui peuvent compenser une expérience très intense de la vie.

L'extrait **maca** est une plante caractéristique des Andes péruviennes qui augmente la capacité du corps à s'adapter aux facteurs de stress que les personnes actives rencontrent souvent dans leur vie quotidienne, au travail ou pendant le sport. Ces caractéristiques aident le corps et l'esprit à réagir positivement et à surmonter ces situations limites, les empêchant de freiner l'esprit et l'enthousiasme pour une vie dynamique.

Le **ginseng**, connu pour ses effets tonifiants et revitalisants, il est utile en particulier pour le soutien et l'amélioration du bien-être physique et mental, la capacité de se concentrer et de lutter contre la sensation de fatigue et de la fatigue.

Les **vitamines B6** et **B12**, également appelée « vitamine énergie », ce qui contribue à l'amélioration et à l'entretien du système immunitaire, la fonction neurologique, la formation de globules rouges et le métabolisme énergétique.



Caféine



Miel



Ginseng



Propolis



Maca



Gelée royale



Vitamines



## Curiosités sur le monde des abeilles



Les abeilles ne dorment jamais .



En moyenne, battre leurs ailes 200 fois par seconde.



28g de miel est suffisant pour alimenter le vol d'une abeille autour du monde.  
(20 g = 1 cuillère à café)



Le miel est le seul aliment qui comprend toutes les substances nécessaires pour soutenir la vie, y compris des enzymes, des vitamines, des minéraux et de l'eau.

## Etiquette, informations techniques.



**ENERGY DRINK**  
**BEEBAD**  
bad is better

sweetened with **HONEY**  
enriched with **ROYAL JELLY & PROPOLIS**

**JUVENTUS OFFICIAL ENERGY DRINK**

250 ml e 52,5 mg caffeine (250 ml)

NL GEMIDDELDE VOEDINGSWAARDEN / FR VALEURS NUTRITIONNELLES MOYENNES	/ 100 ml	/ 250 ml
ENERGIE	192 kJ 45 kcal	480 kJ 112,5 kcal
VET / GRAISSE waarvan verzadigde vetzuren / dont acides gras saturés	0 g 0 g	0 g 0 g
KOOLHYDRATEN / CARBOHYDRATES waarvan suikers / dont sucre	11 g 11 g	27,5 g 27,5 g
EIWITTEN / PROTÉINES	0 g	0 g
ZOUT / SEL	0 g	0 g
Vitamine B3	250 ml = 125 % ADH	8 mg 20 mg
Vitamine B5	250 ml = 83 % ADH	2 mg 5 mg
Vitamine B6	250 ml = 250 % ADH	1,4 mg 3,5 mg
Vitamine B12	250 ml = 100 % ADH	1 µg 2,5 µg
Cafeïne/ Caféine		21 mg 52,5 mg

ADH = aanbevolen dagelijkse hoeveelheid / ANC = apports nutritionnels conseillés  
Koel en droog bewaren. Ten minste houdbaar tot: zie blik  
Conserver dans un endroit sec et tempéré. A consumer avant le: voit bouteille

**BEEBAD® ENERGY DRINK**  
KOOLZUURHOUDENDE ENERGIEDRANK MET HONING, CAFÉINE, KONINGINNEBRIJ, PROPOLIS EN VITAMINEN. GEPASTEURISEERD. GLUTENVRIJ.  
Hoog cafeïnegehalte (21mg/100ml). Niet aanbevolen voor kinderen en vrouwen die zwanger zijn of borstvoeding geven.  
Ingrediënten: koolzuurhoudend water, honing (13,8%), voedingszuur: citroenzuur, natuurlijke aroma's, cafeïne (0,021%), koninginnebrij (0,01%), propolis (0,01%), ginseng extract (0,01%), maca extract (0,01%), vitamines: vitamine B3, vitamine B5, vitamine B6 en vitamine B12.

**BOISSON GAZÉIFIÉE ÉNERGÉTIQUE AVEC MIEL, CAFÉINE, GELÉE ROYALE, PROPOLIS ET VITAMINES. PASTEURISÉ. SANS GLUTEN.**  
Teneur élevée en caféine (21mg/100ml), déconseillé aux enfants et aux femmes enceintes ou allaitantes.  
Ingrediënten: eau gazéifiée, miel (13,8%), acidifiant: acide citrique, arôme naturels, caféine (0,021%), gelée royale (0,01%), propolis (0,01%), extrait de ginseng (0,01%), extrait de maca (0,01%), vitamines: vitamine B3, vitamine B5, vitamine B6 et vitamine B12.

✓ PRODUCT OF ITALY  
✓ GLUTEN FREE  
✓ TAURINE FREE

FRA BEL 2 AILU

Produced for: MM S.r.l. Via Trieste, 25 - 17047 Vado Ligure (SV) Italy.  
fra@beebad.com - bel@beebad.com - www.beebad.com

8 40563261430207

# Analyses et Placement



Competitors:  
 Pas naturel  
 Goût: Pas bon

BeeBad:  
 Naturel  
 Goût: très bon



-   
 Caffeina
-   
 Miele
-   
 Ginseng
-   
 Propoli
-   
 Maca
-   
 Pappa Reale
-   
 Vitamine

**BEEBAD is better**

BEEBAD est la boisson énergétique parfaite au bon moment:



Réelle demande croissante d'ingrédients naturels par les consommateurs.



Energie pure et exempte de sucres raffinés, sans taurine et produit en Italie et sans gluten.



Etudiants, travailleurs et athlètes âgés de 18-34 ans, qui jouent une vie trépidante et exigent des produits sains capables de les soutenir.



Boisson énergisante unique sur le marché avec un goût agréable ,goût frais, rafraîchissant, pétillant et doux.

# Partnership





04.08.2017 11:00 - in: Sponsors

## Beebad Official Partner di Juventus

Condividi con:   

Siglatra per il triennio 2017-2020 la partnership con Beebad: il primo energy drink completamente naturale



A poche settimane dall'inizio della nuova stagione, **Juventus** presenta un nuovo partner: si tratta di **Beebad**, un energy drink che si posiziona in modo unico sul mercato. Si tratta, infatti, di un prodotto premium, a base di miele e altri elementi naturali (caffaina, pappa reale, ginseng, propoli, maca) e arricchito di vitamine B6-B12, ideale per lo sport e per mantenere la concentrazione mentale.

**Beebad** nasce da una formula innovativa, frutto di anni di ricerca di sviluppo ad opera di **Parodi Group**, azienda che dal 1918 è leader nella produzione di miele per uso alimentare, cosmetico e farmaceutico e che, seguendo un'indole orientata a una crescita globale e all'innovazione, si è inserita con questo brand in un nuovo segmento di mercato.

**Beebad** rappresenta per **Juventus** un partner d'eccellenza a livello globale, grazie soprattutto alla sua forte presenza nell'intero continente americano, soprattutto in **Sud America**, e in **Europa**.



THREE MEMBERSHIPS,  
TWO COLORS, ONE TEAM.

SCOPRI DI PIÙ



SATURDAY, AUGUST 5, 2017 • 5:30PM  
Wembley Stadium connected by EE



Estremamente soddisfatto di questo accordo è il **COO di Parodi Group, Santiago Herrero**, che rappresenta **Beebad**: «Abbiamo scelto Juventus come partner perché condividiamo un'identità comune. **Juventus e Beebad sono ambasciatori del made in Italy per l'eccellenza, la perseveranza, l'ambizione e il coraggio**. Abbiamo riscontrato un'analogia tra il lavoro di team del club bianconero e quello, che conosciamo bene, delle api, che lavorano sempre in squadra, raggiungendo risultati concreti grazie ad un'opera instancabile di difesa, attacco e costruzione».



«Siamo molto felici di cominciare una nuova collaborazione con un brand che si posiziona sul mercato internazionale con un prodotto innovativo come Beebad» - commenta **Giorgio Ricci**, Co-Chief Revenue Officer e Head of Global Partnerships and Corporate Revenues di Juventus - «Un brand giovane, in forte crescita, che ha nel suo DNA la propensione a sperimentare, che si fa portatore di concetti comuni a quelli di Juventus: l'autenticità, l'energia, lo sforzo, la continua tensione verso il raggiungimento di nuovi obiettivi, soprattutto in ambito internazionale. **Il fatto che Beebad abbia scelto il nostro Club come partner per veicolare questi valori, ci rende ovviamente orgogliosi**».

Condividi con:   



**JUVENTUS  
OFFICIAL  
ENERGY DRINK**



✓ BE BOLD ✓ BE UNSTOPPABLE ✓ BE JUVENTUS ✓ BE DIFFERENT ✓ BE BRAVE



✓ INGREDIENTI NATURALI ✓ SENZA TAURINA ✓ SENZA ZUCCHERI RAFFINATI ✓ DOLCIFICATO SOLO CON MIELE ✓ SENZA GLUTINE

**Unique identity** 

**BEEBAD**  
bad is better!

 #beebad, #badisbetter, #beesneversleep [www.beebad.com](http://www.beebad.com)

[http://www.ilsecoloxix.it/p/savona/2017/08/04/ASyr4Lil-naturale\\_dissestera\\_beebad.shtml](http://www.ilsecoloxix.it/p/savona/2017/08/04/ASyr4Lil-naturale_dissestera_beebad.shtml)

<http://jmania.it/beebad-juventus-assieme-2020/>

<https://amp.calciomercato.com/news/juve-nuovo-sponsor-fino-al-2020-accordo-con-beebad-un-energy-dri-28099>

<http://lajugadafinanciera.com/juventus-beebad-patrocinio-2017/>

<http://telenord.it/2017/08/04/luna-di-miele-tra-vado-ligure-e-juventus-beebad-diventa-partner-bianconero/>

<http://www.sportspromedia.com/news/juventus-score-beebad-deal>

<http://www.ecodisavona.it/beebead-e-juventus-insieme-fino-al-2020/>

<http://www.mondobianconero.com/tag/beebad/>

<http://247.libero.it/rfocus/32516159/1/luna-di-miele-tra-vado-ligure-e-juventus-beebad-diventa-partner-bianconero/>

<http://www.liguria24.it/2017/08/04/dopo-noberasco-un-altro-sponsor-savonese-per-la-juventus-accordo-con-lenergy-drink-beebad/78339/>

<http://www.publicnow.com/view/D45F1CD5BD7F841D249D555AE11082B73DE5A27C2017-08-04-13:30:08+01:00-xxx236>

<http://www.4-traders.com/amp/JUVENTUS-FOOTBALL-CLUB-SP-95660/news/sponsor-Beebad-becomes-Official-Juventus-Partner-24886204/>

<https://www.ammassi.it/notizie/2017/08/04/juve-nuovo-sponsor-fino-al-2020-accordo-con-beebad-un-energy-drink/amp/>

<https://www.ecofoot.fr/juventus-contrat-sponsoring-beebad-2272/>

<http://stellebianconere.eu/sezioni/ravenna/>

<http://www.sportbusinessmanagement.it/?m=1>

<https://vado-ligure.virgilio.it/notizielocali/>

<http://www.sanfiorianconero.com/>

<http://www.svolta.net/>

<http://www.juventusclubmodena.it/>

<http://www.forzajuve.ru/news/beebad-noviy-partner-juventusa.html>

<https://syndication.bleacherreport.com/amp/juventus>

<http://forza.hateblo.jp/entry/2017/08/04/195834>

<http://www.juventus.com/threads/20446-The-Financial-Situation?p=5583629>

[http://espn.uol.com.br/time/juventus/social\\_timeline?start\\_id=instagram%3A1573881086071621384\\_194317179](http://espn.uol.com.br/time/juventus/social_timeline?start_id=instagram%3A1573881086071621384_194317179)

<http://c3writing.com/data/tribalfootball/654535/sweet+move+for+juventus+and+energy+drink>

<http://www.juventusg.ch/verein/vorstand.html>

<http://www.torinoggi.it/mobile/tutte-le-notizie.html>

<http://www.campioni.cn/mobile.html>

<http://www.tribalfootball.com/articles/sweet-move-for-juventus-and-energy-drink-4193262>

<http://italy.shafaqna.com/IT/IT/548350>

<http://www.juventus.be/>

<http://www.juvebros.com/sedial-eiusmod-tempor/>

[https://vk.com/forzajuve\\_ru](https://vk.com/forzajuve_ru)

<https://bbs.hupu.com/19920881.html>

<https://topsy.one/hashtag.php?q=%23JUVE>

P.O.P

## Plateau personnalisé



### Plateau personnalisé

Capacité: 24 canettes x 250ml

Mesures: mm 215 x 325 x 45 h

Poids canette: 0,27 kg

Poids plateau: 6,658 kg

## CONDITIONNEMENT

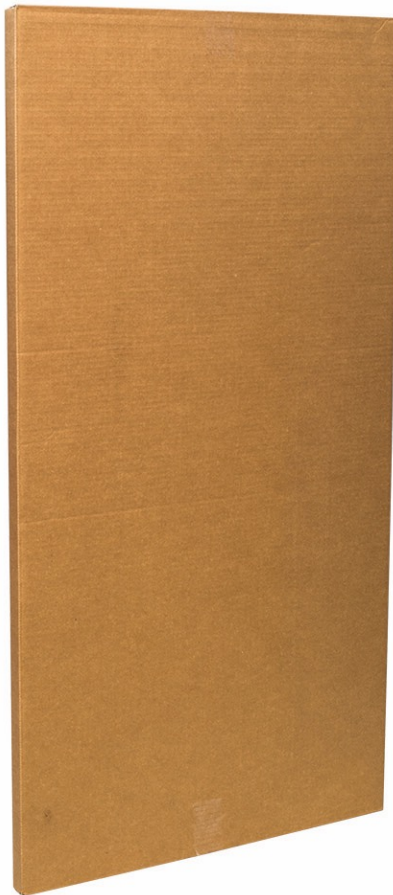

### CONDITIONNEMENT

cm 99 x 123,5 x 3,5





## Fiche technique expositor

Onda EB  
crownner

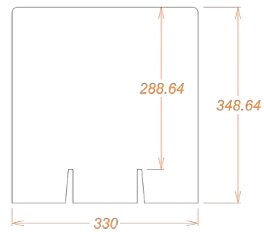

Onda EB  
fronte + laterali

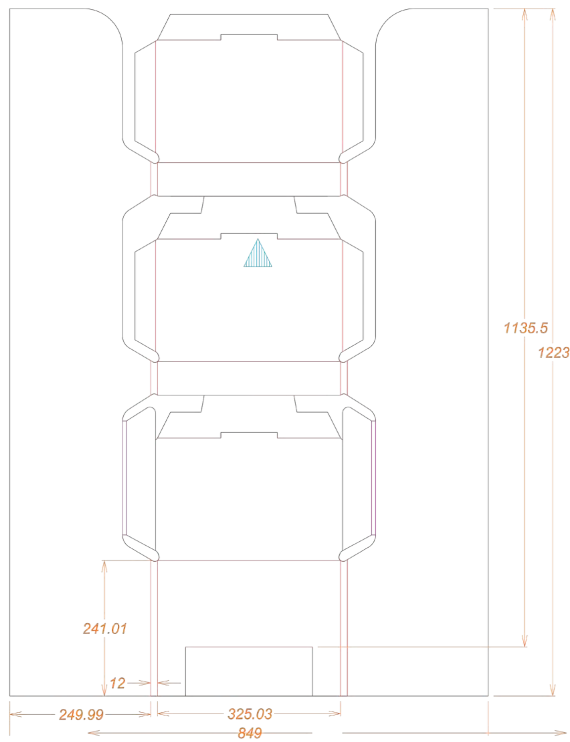

Onda EB  
schiena

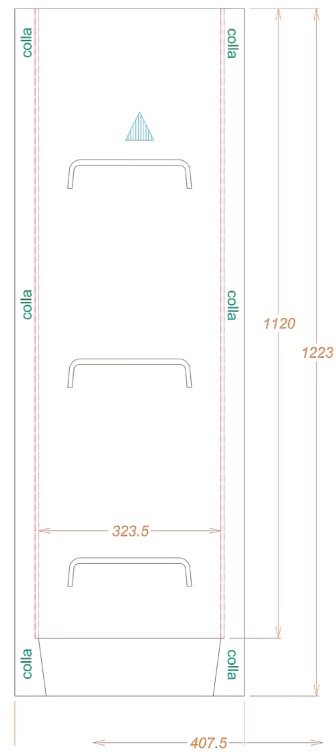

## COMPONENTI PER SPEDIZIONE STESO

Onda B  
Imballo per spedizione steso

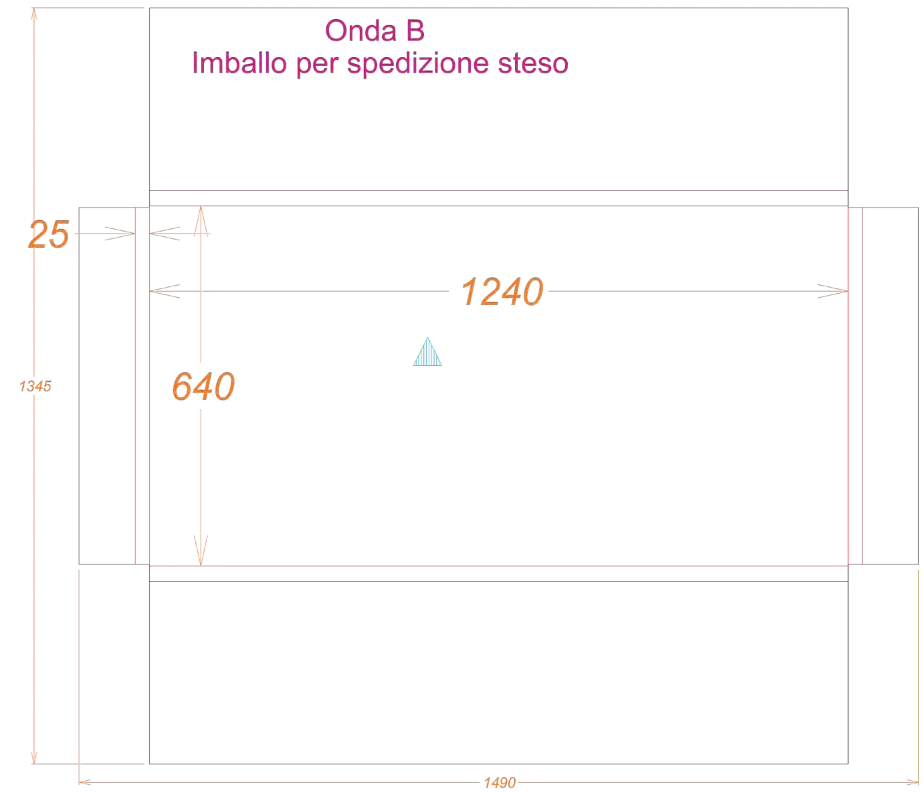

## Expositor pre-chargé



### CONDITIONNEMENT

cm 27 x 35,5 x 114h

**Poids expositor vide totale:** 5,35 kg

Corp: 1,31 kg

Crowner: 0,085 kg

Capot: 0,765 kg

Croisière: 0,09 kg

Compensateurs x 0,105 kg (x 2)

Minipalettes: tra i 2,5 e 3 kg c/u



### EXPOSITOR

#### Measures

Hauteur totale: cm 151,5

Crowner: cm 29,5 h

Hauteur zone chargement: cm 122

Profondeur: cm 25

Largeur: cm 34,5

#### Poids

Expositor chargé: 45,295 kg

6 plateau: 39,94 kg

#### Livraison

Expositor pre-chargé avec

6 plateau de 24 canettes c/u

#### Code EAN



8 056326 430146

## Fiche Technique expositor pre-charge

### COMPONENTI PER SPEDIZIONE MONTATO CON PRODOTTO

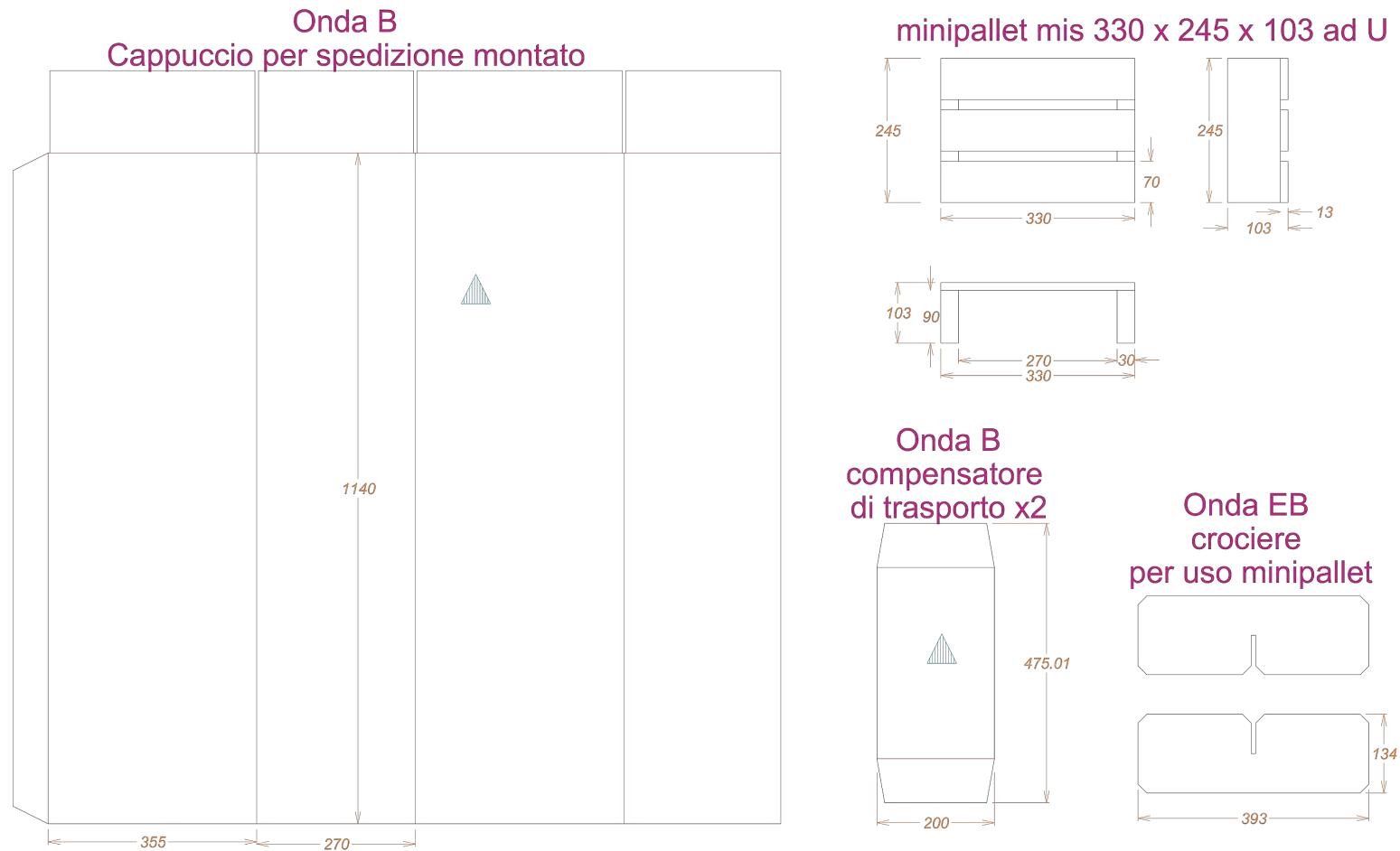

## Pallettiseur

mm 800 x 1200  
8 expositor par la couche  
N° couches PLT max: 1

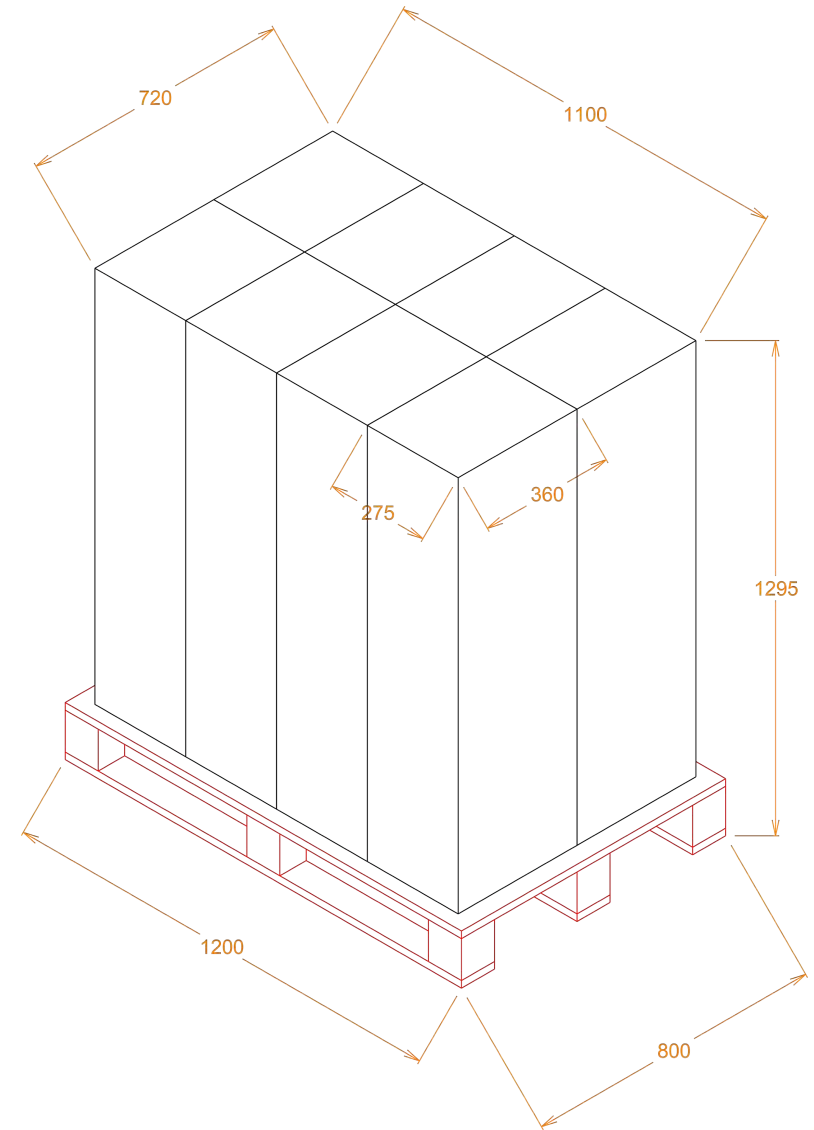

## Refrigerateur 50lt



Illuminazione interna  
e backlight sul logo frontale



# Communication

[www.beebad.com](http://www.beebad.com) et Social Media  
(Instagram et Facebook)

BEEBAD È IL PRIMO ENERGY DRINK MADE IN ITALY, DOLCIFICATO ESCLUSIVAMENTE CON MIELE E COMPOSTO UNICAMENTE DA INGREDIENTI SANI E NATURALI. INOLTRE, È ARRICCHITO CON VITAMINE B6 E B12. IL SUO GUSTO UNICO, FRESCO, BUONO E LEGGERMENTE FRIZZANTE LA RENDE UNA DELLE MIGLIORI BEVANDE ENERGETICHE A BASE DI INGREDIENTI NATURALI.

PURE ENERGY

L'ENERGY DRINK  
POTENTE PER NATURA

## BEES NEVER SLEEP UPCOMING EVENTS

30.09.2017 - WAKEUP Music Event  
 2017 - Mendicivine Outlet Village

05.07.08.10. 2017 - Swim the Island  
 Savona



## BEES NEVER SLEEP PAST EVENTS

- TUTTO
- 2016
- 2017
- ALTRI SPORT
- BEACH VOLLEY
- BEEBAD AROUND THE WORLD
- BIKING
- CROSSFIT
- CULTURA
- PARTY
- RUNNING
- SUMMER RACE





# OGNI GIORNO STAY TUNED SUCCEDA TANTO!

BEEBAD e SWIMTHEISLAND #7. Per voi, swimmers, un bellissimo ricordo pieno di energia ed emozioni. #beebad #beebadenergydrink #energia #swimming #beesneverleep #badisbetter #swimtheisland7 | #bergeggi #jakedofficial #see #riviera #spotorno #isola #swim #sport #fun #sun #beach

[BeeBad Energy Drink Italia](#)

Posted 22 hrs + 9 mins ago

Ecco il bellissimo report fotografico di due giornate stupende. Avanti con i tag! #beebad #beebadenergydrink #energia #swimming #beesneverleep #badisbetter #swimtheisland7 | #bergeggi #jakedofficial #see #riviera #spotorno #isola #swim #sport #fun #sun #beach

[BeeBad Energy Drink Italia](#)

Posted 1 day + 1 hr ago

🔥🔥 Autumn season @smatte15 @bike\_hike\_spotorno #autumn #season #mountainbike #allmountain #crosscountry #enduro #trail #biketral #nature #wood #ebike #liguria #outdoors #sport

#natureworld\_photography #mountains #mountaintop #trees #tree #followfollow #follow #helthyiving #helthylife #beebad #energy #energydrink #badisbetter

[beebaditalia](#)

Posted 1 day + 2 hrs ago

#beebad ringrazia @paolocciavito39 per la foto mandate i vostri #scatti | Send your #shots | #natural #nature #natura #sea #seaside #bigblue #mare #riviera #liguriansea #liguria #ligurian\_places #liguriabestsunset #italy #madeinitaly #relax #relaxing #relax 😊

[beebaditalia](#)

Posted 1 day + 18 hrs ago

#dance #beebad #badisbetter #beesneverleep #danza #freestyle #freestylrap #hiphop

#danzacontemporanea #music #musica #dancing #rythm #enjoy #fun #street #energy

[beebaditalia](#)

Posted 2 days + 21 hrs ago

Wake up 2017 📌📌📌 @wakeupmusicvents #martingarrx #wakeup #wakeup2017 #bestdj #music #musicvideo #live #musiclive #party #partytime #beesneverleep #lighting #lightlife #djset #followfollow #toptags #instamusic #beebad #badisbetter

[beebaditalia](#)

Posted 3 days + 23 hrs ago

Giornata incredibile di sport natura e passione per la 7ª edizione di SWIMTHEISLAND e #beebad #badisbetter #beesneverleep #beescanswim Spotorno Bergoggi Isola di Bergoggi Riserva naturale regionale di Bergoggi Liguria, Italy Liguria Sea Swimming Swimmers

[BeeBad Energy Drink Italia](#)

Posted 4 days + 20 hrs ago

#beebad #befun #badisbetter #beesneverleep #enjoywhatyoudo #enjoy #enjoyyourlife #behappy #happy #joy #happiness #sweet #hair #lifeisgood #gifts #thewayweare

[BeeBad Energy Drink Italia](#)

Posted 1 day + 21 hrs ago

#swimtheisland #swimtheisland7 #beebad #beesneverleep #badisbetter #sea

#swimtheisland #swimtheisland7 #beebad #beesneverleep #badisbetter #sea

## SOCIAL MEDIA - RUBRIQUES



Places to Bee

Le onde migliori per la tua adrenalina le trovi in qui, in questa località di Fuerteventura nota per le immense dune di sabbia bianche...dove siamo?



Inside Bee

Volevamo distinguerci e l'abbiamo fatto partendo dalle basi!



Bee Coach

Da oggi a fine anno, muovi le chiappe e inizia con una serie di 30 piegamenti 3 volte alla settimana. Ed è solo l'inizio!



Maestro EN-ER-JI

Da una località lontanissima arriva Maestro EN-ER-JI a portare un po' di senso a chi il senso l'ha perduto.



Quando sei così scarico che

Cosa fai a capodanno? Ogni anno la solita storia, che inizia sempre a partire da settembre...



Inside Bee

Abbassa i livelli di glicemia. Ha proprietà antiossidante e pare sia un ottimo afrodisiaco...ed è uno dei nostri ingredienti. Di cosa stiamo parlando?

# ÉVÉNEMENTS 2016-2017

## ÉVÉNEMENTS 2016

27-28-29/5: INTERNATIONAL 24H FINALE - BIKE (Finale Ligure-Savona)

4-5/6: RALLY DI ALBA (Alba-Piemonte)

TRIREG - CONFINDUSTRIA (sponsor tecnico)

10-11/6: SANTA RUN - RUNNING (sponsor technique) (Santa Margherita Ligure-Genova)

9/7: LIGURIA BOX BATTLE - CROSSFIT (Recco- Genova)

16/9: BEEBAD YELLOW NIGHT - OUTDOOR PARTY (PARCO DEL BEIGUA)

24/9: BEEBAD SPORT - EVENTO AD HOC -SPONSOR TECHNIQUE MULTIDISCIPLINAIRE  
(comune di Sassello)

29/9: FIESTA en DISCOTECA, La Sosta di Campobasso

3-10-17/9: WAKE UP MUSIC EVENTS 2016 - DANCE PARTY (MONDOVÌ)

17/9: NAVE ITALIA - HAPPY HOUR (ACQUARIO DE GENOVA)

17/9: DOWNHILL OSA - BIKE

9/10: BEEBAD HARD RACE - MOTOCROSS (PAROLDO)

9/10: RUNNING (Priàmar, Savona)

31/10: WAKE UP HALLOWEEN PARTY. DANCE (Mondovì)

31/10 : LA SOIREE PALACE Halloween party (Genova)

5-6/11: LA BATALLA DE LOS ALPES. Crossfit

5-6/12: FALL SERIES - CROSSFIT COMPETITION

18/12: CHRISTMAS NIGHT - RUNNING (SAVONA)





**BEE-BAD**  
HONEY  
NATURALLY SWEET  
ELECTROLYTE

GORE-TEX

LEVEL

MAESTRO DI SCI  
PIEMONTE

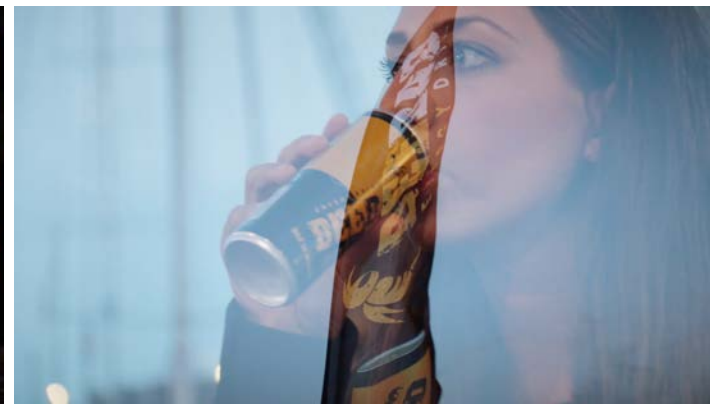
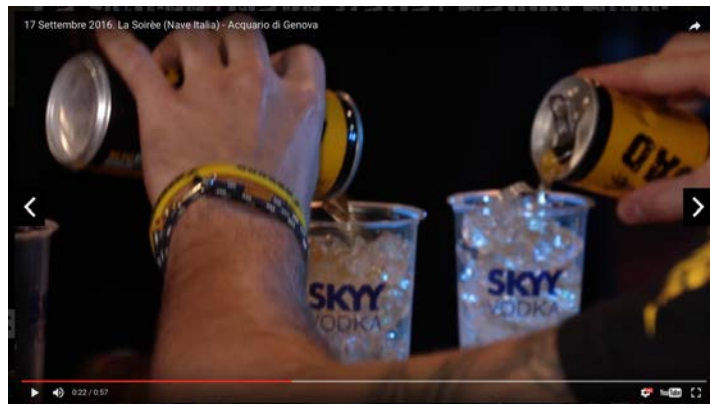
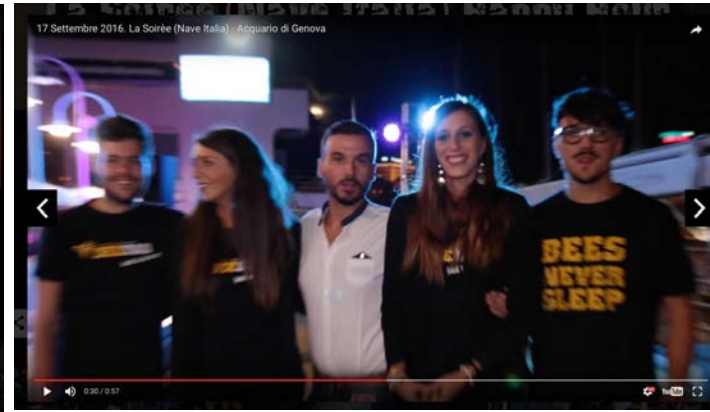







## ÉVÉNEMENTS (Janvier-Octobre)

- 6-7/2: Brixia Throwdown, Brescia. Crossfit
- 25-26 /2 CAMPIONATO regionale FISU Liguria - SCI ALPINO, Lurisia. Sci
- 7-8-9/4: LA MEZZA DI GENOVA, Running
- 21/4: Whats a Block, Savona. Arrampicata
- 23/5: Silent Street Workout. Genova. Street workout
- 25/4: SUP Beach Race, Cecina. Sup - Surf
- 30/5: Evento Konka Verde DownHill, Savona. DownHill
- 30/5: Evento Partnership con Comma9, Genova (righi). MTB e DownHill
- 7/5: Liguria Grappling Open, Varazze. Arti Marziali
- 7/5: Street Workout Genova, Genova. Running e Fitness
- 19/5: Varazze di sera, Varazze. Running
- 21/5: BBQ Ride, Varazze (Monte Beigua). MTB e DownHill
- 24-25-26-27-28/5:  
PACHA , Montecarlo. Dance  
GP F1 Monaco, Montecarlo. Formula 1
- 27-28/5: Roma Throwdown, Roma. Crossfit
- 27-28/5: In3pid Triathlon Noli, Noli. Triathlon
- 2/6: Festa del LICEO SCIENTIFICO (KAVA), Bergoggi. Dance
- 9/6: FESTA DELLO STUDENTE SOLELUNA, Albissola Marina. Dance
- 10-11/6: Urban Downhill (con COMMA9), Diano Castello. Downhill Urban
- 11/6: Raduno di Jeep, Murialdo. Outdoor Jeep
- 11/6: Festa del LICEO CLASSICO (KAVA), Bergoggi. Dance
- 18/6: Italia Sup League, Cecina. Sup - Surf
- 24-25/6: ION CUP MTB, Savignone. MTB amatoriale
- 24-25/6: One2One Challenge, Torino. Crossfit
- 1-2/7: SUP Beach Race ROMA, Roma. Sup - Surf
- 7/7: Genova Footrace, Genova. Running
- 8/7: Liguria Box Battle, Recco. Crossfit
- 8/7: PARTECIPARTY, Genova (Monte Fasce). Dance
- 9/7: Torneo Water Volley, Vanzago (MI). water volley
- 9/7 : W.A.S Summer race, Savona. Canoa/Surf/Kayak/Sup
- 9/7: Miglio Stella Maris, Camogli (GE). Nuoto
- 06-13-20-27/7: NOTTE Bianca SAVONA, Savona. PROMOZIONE BeeBad
- 22-23/7: East Coast Challenge, Trieste. Crossfit
- 29-30/7: BATTLE OF STARS, Salerno. Crossfit
- 12/8: CorriCasanova - camminata per Ilaria, Genova. Running/Beneficenza
- 14/8: BEEBAD Music Events, Savona (Scaletto). Music
- 18/8: Finale Regionale Miss Italia, Imperia. Models
- 10/9: Race fo Fun, Pian del Poggio (Pavia). Downhill
- 22-23-24/9: Finale Beach Volley, Finale Ligure. Beach Volley
- 22-23-24/9: Savona Half Marathon -Title sponsor 10k - Città dello Sport, Savona. Running
- 7-8/9: La Battaglia di Milano, Milano. Crossfit
- 7/10: SWIM THE ISLAND, Bergoggi.
- 9-10. WAKE UP , Mondovì. Dance
- Tout au long de l'été 2017.  
PARRAINAGE BEACH VOLLEY, Albissola Marina. (22 date beach volley)  
PARRAINAGE GOLDENBEACH - diurno  
PARRAINAGE SOLELUNA BEACH - NIGHT FEVER, Albissola Marina. Dance  
PARRAINAGE A SPASSO NELLA DANCE, regione Liguria. Dance  
PARRAINAGE COMMA9, Genova. MTB Downhill ecc  
PARRAINAGE LOTTATORI MILANO, Milano. Arti Marziali - Fitness



gran bike  
**Palladino**  
ITA  
Zoot  
LAURETANA  
inspid  
34  
INSPID Triathlon Offroad 2011

gran bike  
**RANIERI**  
ITA  
Zoot  
LAURETANA  
inspid  
34  
INSPID Triathlon Offroad 2011

gran bike  
**BRANGERO**  
ITA  
Zoot  
LAURETANA  
inspid  
30  
INSPID Triathlon Offroad 2011







BEEBAD  
ENERGY DRINK

bad is better

ENERGY DRINK  
BEEBAD  
HONEY

ENERGY DRINK  
BEEBAD  
bad is better

mdg  
mezza | genova

mdg  
mezza | genova

mdg  
mezza | genova

mdg  
mezza | genova

BEEBAD  
HONEY

BEEBAD  
HONEY

BEEBAD  
HONEY

BEEBAD  
HONEY

AFRICA  
& SPORT

AFRICA  
& SPORT

LOIPERSDORF

amur

amur

amur

amur

amur

amur

amur

amur

amur

amur

amur

amur

amur

amur

amur

amur

amur

amur



# Actions de Mktg Supermarchés

Expositor personnalisé  
Dégustations avec hostess





# COMMUNICATION DANS LES SUPERMARCHES



Magazine Amica

Site TIGROS

**FINALMENTE  
 UN ENERGY DRINK  
 DAVVERO BUONO  
 E DOLCIFICATO  
 SOLO CON MIELE!**

- ✓ SENZA ZUCCHERI RAFFINATI
- ✓ SENZA GLUTINE
- ✓ SENZA TAURINA



**BEEBAD<sup>®</sup> energy drink: ingredienti naturali  
 gusto unico, fresco, morbido e frizzante.**



Miele



Ginseng



Propoli



Maca



Pappa Reale



Vitamine

[www.beebad.com](http://www.beebad.com)

[f](#) [@](#) #Beebad



MM 51 - Via Trieste, 25 - 13047 Vado Ligure (CS) - Italia

**FINALMENTE  
 UN ENERGY DRINK  
 DAVVERO BUONO  
 E DOLCIFICATO  
 SOLO CON MIELE!**

- ✓ DAL GUSTO BUONO
- ✓ SENZA ZUCCHERI RAFFINATI
- ✓ SENZA GLUTINE
- ✓ SENZA TAURINA



**Energy drink dal sapore fresco, morbido e frizzante.  
 A base di ingredienti naturali:**



Caffina



Miele



Ginseng



Propoli



Maca



Pappa Reale



Vitamine



Merci de votre attention